

LISBOA

180° INSTALLATION INSTRUCTIONS

STANDARD SERF2 180 DEGREE KIT INCLUDES:

- One 78-3/4" (2 m) Length Header Support Bar
- Two Rollers
- Two Stoppers
- Two Anti-Lift Fittings
- Two Track Holder Fittings for Wall
- Two Track Holder Fittings for Fixed Panel
- One Thru-Glass Pull
- One Door Guide



Cat. No. SERR2
Rollers (2)



Cat. No. SERS2
Stoppers (2)



Cat. No. SERAL2
Anti-Lift Fittings (2)



Cat. No. SERH2
78-3/4" (2 m) Header
Support Bar.
Low Profile 1-3/16"
(30 mm) Height



Cat. No. SERP2
Thru-Glass Pull



Cat. No. SERW2
Track Holder Fittings
for Wall (2)



Cat. No. SERFP2
Track Holder Fittings
for Fixed Panel (2)



Cat. No. SERDG2
Door Guide

- 1) The Header Support Bar is positioned exactly in the middle of the sliding door and fixed panel. There is a 1-1/8" (29 mm) gap between the sliding door and the fixed panel. Therefore, from the middle of the Header Support Bar to the surface of the sliding door or fixed panel glass, the distance is 9/16" (14 mm). The Header Support Bar is generally mounted in the center of the vertical jamb. Note: Due to the extremely smooth nature of the rollers, the Header Support Bar must be installed level. Failure to do so could result in a sliding door that rolls to one side by itself!
- 2) To locate the holes in the vertical walls for mounting the Header Support Bar, take the intended overall height to the top of the glass and deduct 3" (76 mm). This figure will represent the height location from the curb to the center of the holes to be drilled in the vertical walls. Drill the holes and mount the Track Holder Fitting blocks to each side wall.
- 3) Determine the location of the fixed panel on the curb. As a guideline, use the figure of 9/16" (14 mm) from the center of your Header Support Bar to the inside face of the fixed panel glass. However, if the fixed glass is mounted on the inside of the enclosure, the 9/16" (14 mm) dimension is to the outside face of the fixed panel glass.
- 4) Fasten clamps or U-channel (the method of securing the fixed panel) to the curb.
- 5) Cut the Header Support Bar 1" (25 mm) shorter than the wall-to-wall tight dimension where the track is to be mounted. Please Note: The Header Support Bar is made of stainless steel. Either a hand-held hacksaw or special cutting tools should be used.
- 6) On the fixed panel, measure from the edge of the glass that butts the wall to the center of the holes in the fixed panel of glass at the top, and determine the correct location to set the connectors into the Header Support Bar.

LISBOA

- 7) Using the location to the center of the holes in the fixed panel glass, add the pre-determined clearance allotted between the fixed glass and the vertical wall to which the fixed panel butts. These figures will determine exactly where the holes will be located in the Header Support Bar. For example: If the center of the hole at the top of the glass is located 3-1/2" (89 mm) in from the wall-butting edge and a clearance between the glass and the wall has been set at 1/8" (3 mm), the hole location for the connector would be set at 3-5/8" (92 mm) in from the wall.
- 8) The Header Support Bar was cut down 1" (25 mm) from the tight opening dimension in Step 5. This 1" (25 mm) deduction is allocated as 1/2" (13 mm) off each end. When measuring the Header Support Bar to drill the holes for the Track Holder Fittings for Fixed Panel, this 1/2" (13 mm) deduction must be taken into consideration. Using the dimensions calculated in Step 7, deduct the 1/2" (13 mm) required when measuring from the end of the Header Support Bar to mark where the holes for the connectors are to be drilled. In the example used in Step 7 the first hole in the Header Support Bar should be located 3-5/8" (92 mm) in from the wall to the center of the hole. Deduct 1/2" (13 mm) and drill the hole at 3-1/8" (79 mm) in from the end of the Bar to the center of the hole.
- 9) The diameter of the clearance holes for the Track Holder Fitting for Fixed Panel is 1/4" (6 mm). The holes are to be drilled directly in the center of the Header Support Bar.
- 10) The Header Support Bar is to be permanently mounted. Prior to permanently mounting the Header Support Bar, slide a Stopper on each end (with the rubber bumper portion toward the ceiling), then slide a Track Holder Fitting for Wall on each end (set screws facing to the ceiling). Carefully place the Header Support Bar in place between the Track Holder Fitting blocks.
- 11) Slide both Track Holder Fittings from the Header Support Bar to the blocks mounted to the wall. Tighten the set screw closest to the wall to hold the Track Holder Fittings tightly to the mounting blocks.
- 12) Before setting the fixed panel and permanently fastening it to the header, carefully slide the Stopper on the fixed panel side of the Header Support Bar to a midway position between the two holes drilled in the Header Support Bar.
- 13) The fixed panel can be fastened to the base/curb and positioned to the Header Support Bar. With the fixed panel in place, fasten the Track Holder Fittings for Fixed Panel attaching the glass to the Header Support Bar.
- 14) Attach the Rollers to the sliding door glass, making sure to use the longer screws for 3/8" (10 mm) glass or the shorter ones for 5/16" (8 mm) glass. The Rollers should be adjusted to the center of their "out-of-round" position. This allows for adjusting the Rollers more easily if needed.
- 15) Carefully hang the door on top of the Header Support Bar. Slowly roll the door to check for the correct fit and adjust the Rollers if needed.
- 16) With the door hanging on the Header Support Bar and in the closed position, place the bottom guide to the desired location. Mark the base/curb by outlining around the bottom guide. Remove the door and carefully set aside.
- 17) Place the guide in the correct position and mark the base/curb for drilling. Mount the guide.
- 18) Re-hang the door, placing the glass inside the guide.
- 19) Fasten the Anti-Lift Fittings through the door glass. Adjust the Anti-Lift Fittings to allow the rubber ring to ride 1/16" (2 mm) below the Header Support Bar.
- 20) Attach Through Glass Pull to door. Simply unscrew the (2) halves of the pull and thread them together in the 2" (51 mm) hole in the sliding door glass.

LISBOA

GLASS AND METAL CUTTING FORMULA FOR 180 DEGREE APPLICATION

SPECIFICATIONS:

- Overall width = Wall to wall distance
- Overall height = Height from curb to top of glass
- Glass panels extend 2-7/16" (62 mm) above top of the header
- Fixed glass height formula is based on using "U" Channel or Clamps.
A 3/16" (5 mm) standard deduction is used at the bottom of the fixed panel.
- Fixed and sliding glass panels overlap 2" (51 mm)
- Standard gap between wall and fixed and/or sliding glass is 1/8" (3 mm)
- Header height is 1-3/16" (30 mm)
- Gap between fixed and sliding glass panels is 1-1/8" (29 mm)
- Sliding glass height formula is based on using a 5/16" (8 mm) standard deduction at the bottom

METAL SIZE CUTTING FORMULA:

- Header = Overall width measurement less 1" (25 mm)

GLASS SIZE CUTTING FORMULA:

- Width of fixed and/or sliding glass =
Overall width divided by 2, plus 7/8" (22 mm)
- Height of fixed glass = Overall height - 3/16" (5 mm)*
- Height of sliding glass = Overall height - 5/16" (8 mm)*
- Door Pull SERP2 is centered vertically
- * Reminder - Overall height is determined from curb to top of glass

Cross-Section Serenity Sliding Door Kit

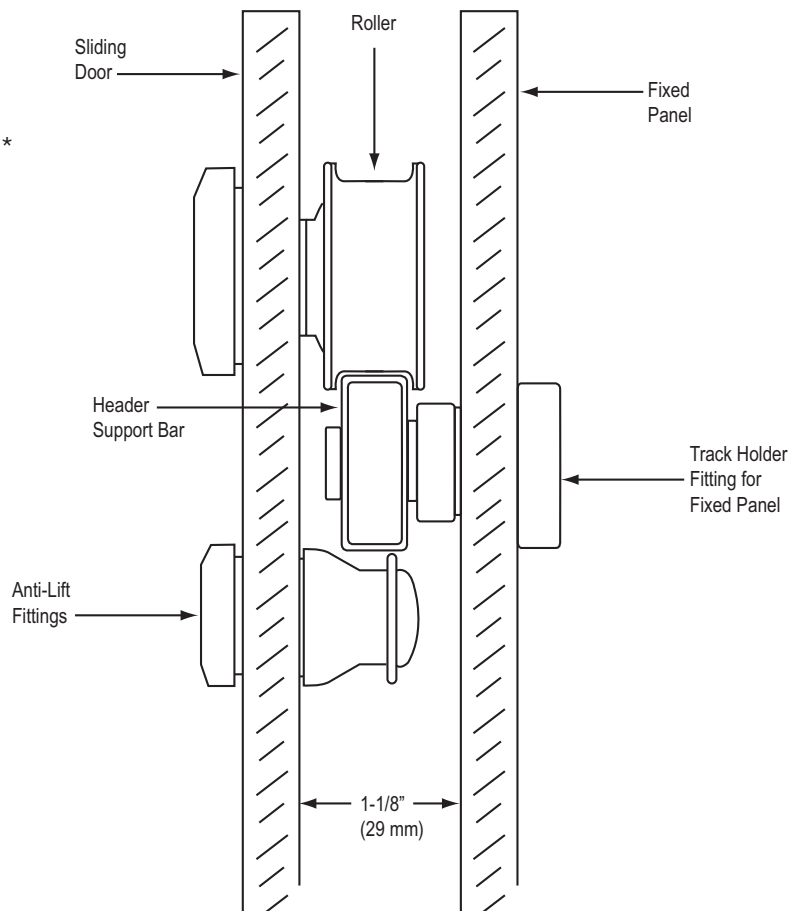

LISBOA

GLASS AND METAL CUTTING FORMULA FOR 180 DEGREE APPLICATION

